

Smart Tank using Raspberry Pi

Ms. Kumbhar K A¹, Manasi Sangvikar², Sherin Tikko³

Assistant Professor, E & TC Department, VIIT, Pune, India¹

E & TC Department, VIIT, Pune, India^{2,3}

Abstract: Ended up primarily concentrating on looking at unusual display technologies and decided that a Smart Tank would be a good balance of hardware and software. This simulates four sensors to sense the water parameters i.e. temperature ,level, hardness and turbidity This has limited hardware interaction but is slightly complex on the software side or need to be connected to internet then we should just go with Raspberry Pi. Also need to program using variety of programming languages (not limited to C/C++), therefore choosing Raspberry Pi.

Keywords: Temperature, level, hardness and turbidity, Raspberry Pi.

I. INTRODUCTION

Here to implement this following are some steps Sensor interfacing, then Python coding, Use of advance technology like raspberry pi then sent it through Application like IOT.

INTERNET OF THINGS (IoT):

Sending data accumulated by sensor to user without actual contact between the two.

II. LAYOUT

Temperature Sensor

DS18B20, temperature sensor used to sense the temperature of water.

Level Sensor

Floating sensor acting as switch used to sense level of liquid.

I – V converter

Current-to-voltage converter, most often implemented using an operational amplifier is used to amplify^[1] the current output of float sensor to a usable voltage.

Current-to-voltage converters are used with sensors that have a current response that is more linear than the voltage response.

Converts the low-level current of a sensor to a voltage.

Hardness Sensor (TDS Sensor)

Used to determine total dissolved salts.Total dissolve solids are total amount of mobile charged ions including minerals salts or metal dissolve in a given volume of water expressed in units of parts per million(PPM). TDS is directly related to purity of water. In general TDS is sum of cations and anions present in water.

Turbidity Sensor

Photo detector used to measure turbidity of liquid. Pass the light through water if it scatters; water is turbid otherwise it's not.

ADC; used to convert analog output of photo detector to digital input signal for raspberry pi.

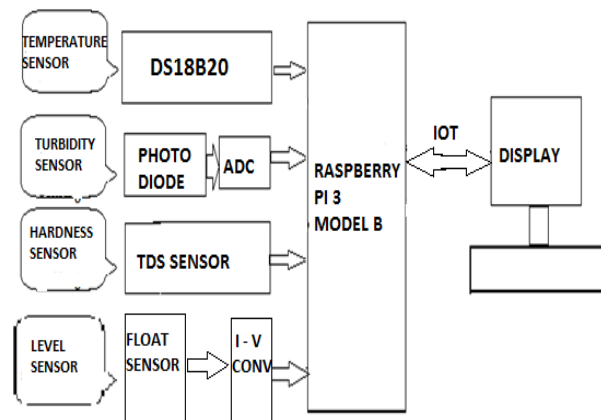

Raspberry Pi

This has limited hardware interaction but is slightly complex on the software side or need to be connected to internet then we should just go with Raspberry Pi. Also Want to program using variety of programming languages (not limited to C/C++), then we are choosing Raspberry Pi. The Pi 3 adds support for 802.11n Wi-Fi and Bluetooth 4.1 to the board

III. ELECTRONIC AND HARDWARE DESIGN ASPECTS

SOFTWARE ASPECTS

PROTEUS:

It is software for microprocessor simulation, schematic capture. It is developed by Lab center electronics. The proteus design suite includes schematic capture tool with the Possibility to simulate programmable ICs like Microchip PIC, Atmel AVR etc. ARES for PCB layouts.

ALTIUM 13:

Altium 13 software is used for routing tracks of PCBs. It is a useful software as it has many In-built libraries. so we do not have to separately create our new library and draw a component according to its specification on datasheet. We just have to install the library and use the appropriate components.

RASPBIAN

We are using raspbian as OS for raspberry pi. On windows we need to download an SSH client.

Putty is a free and open-source terminal emulator, serial console and network file transfer application.

It supports several network protocols, including SCP, SSH, Telnet, rlogin, and raw socket connection.

Putty does not have an installer package it's just a standalone .exe file.

An easy way to comply with the conference paper formatting requirements is to use this document as a template and simply type your text into it.

In its simplest form an I to V converter amplifier has just a large-valued feedback resistor, R_f . The gain of the amplifier is set by this resistor and has a value of $-R_f$ (because the amplifier is in an inverting configuration).

Float sensor output is connected as input between ground and the inverting input of the op-amp. The other input of the op-amp is also connected to ground. This provides a low-impedance load for the sensor, which keeps the sensor voltage low. The high gain of the op-amp keeps the sensor current equal to the feedback current through R_f . This permits a large gain without any large output offset voltage. This is used with photodiodes that are illuminated with low light levels and require a lot of gain. The DC and low-frequency gain of a I V converter is determined by the equation

$$-I_p = \frac{V_{out}}{R_f},$$

so

$$\frac{V_{out}}{I_p} = -R_f.$$

- If the gain is large, any input offset voltage at the non-inverting input of the op-amp will result in an output DC offset. An input bias current on the inverting terminal of the op-amp will similarly result in an output offset. To minimize these effects, transimpedance amplifiers are usually designed with FET input op-amps that have very low input offset voltages.^[3]

IV. CONCLUSION

The biggest advantage of this model comes into picture when it is implemented for overhead tanks .First and

foremost there is no need to climb the stairs again and again to check the water level in the tanks.

Secondly no need to go for switching on the water pump as it is automatically done so this in turn reduces manpower involved in monitoring.

Thirdly it has a display screen which shows the current status of the tanks water level indicating not only the maximum and the minimum water level but also an intermediate level of the water.

APPLICATIONS

As its title suggests, it can be very well used for the residential colonies.

This system can be used in chemical industries where fluids are filled in big tanks and their monitoring is required.

It can also be used in nuclear plants where monitoring fluid filled tanks is mandatory as well as should be optimized.

Using IOT we are automating the water tank.

ADVANTAGES

The biggest advantage of this model comes into picture when it is implemented for overhead tanks.

First and foremost there is no need to climb the stairs again and again to check the water level in the tanks.

Secondly no need to go for switching on the water pump as it is automatically done so this in turn reduces manpower involved in monitoring.

REFERENCES

- [1] www.raspbian.org
- [2] www.python.org
- [3] www.alldatasheets.com
- [4] Operational Amplifiers-chapter on all about circuits

BIOGRAPHY



Ms. Kumbhar K A working as Assistant professor in Vishwakarma Institute of Information Technology. Has a published/presented paper in national conferences. Completed Post graduation.